



# Sunny Boy SB 2100TL

## Transformerless solar inverter





# Table of Contents

|          |  |           |
|----------|--|-----------|
| <b>1</b> | <b>Explanation of the Symbols Used</b>   | <b>5</b>  |
| <b>2</b> | <b>Foreword</b>                          | <b>7</b>  |
| 2.1      | Target Group                             | 7         |
| 2.2      | Appropriate Usage                        | 7         |
| <b>3</b> | <b>Safety Instructions</b>               | <b>9</b>  |
| <b>4</b> | <b>Overview</b>                          | <b>11</b> |
| 4.1      | Unit Description                         | 11        |
| 4.2      | External Dimensions                      | 12        |
| <b>5</b> | <b>Installation Requirements</b>         | <b>13</b> |
| 5.1      | Installation Location Requirements       | 13        |
| 5.2      | PV Generator Requirements                | 16        |
| 5.3      | Low Voltage Grid (AC)                    | 16        |
| <b>6</b> | <b>Installation</b>                      | <b>21</b> |
| 6.1      | Mounting the Device                      | 21        |
| 6.2      | Electrical Installation                  | 22        |
| 6.2.1    | Connecting the AC Output                 | 24        |
| 6.2.2    | PV String (DC) Connection                | 30        |
| 6.3      | Commissioning                            | 31        |
| <b>7</b> | <b>Opening and Closing the Sunny Boy</b> | <b>33</b> |
| 7.1      | Opening the Sunny Boy                    | 33        |
| 7.2      | Closing the Sunny Boy                    | 33        |

|           |  |           |
|-----------|--|-----------|
| <b>8</b>  | <b>Technical Data</b> . . . . .                    | <b>35</b> |
| 8.1       | PV Generator Connection Data . . . . .             | 35        |
| 8.2       | Grid Connection Data. . . . .                      | 36        |
| 8.3       | General Data. . . . .                              | 37        |
| 8.4       | Efficiency. . . . .                                | 38        |
| 8.5       | Operating Parameters. . . . .                      | 39        |
| 8.5.1     | Explanation of the Operating Parameters . . . . .  | 39        |
| 8.5.2     | Parameter Settings for Germany . . . . .           | 41        |
| 8.5.3     | Fixed Parameters . . . . .                         | 43        |
| 8.6       | Certificates. . . . .                              | 44        |
| 8.6.1     | CE Declaration of Conformity . . . . .             | 44        |
| 8.6.2     | SMA Grid Guard Certificate . . . . .               | 46        |
| <b>9</b>  | <b>Replacing the Varistors</b> . . . . .           | <b>47</b> |
| <b>10</b> | <b>Rating for a Line Circuit Breaker</b> . . . . . | <b>51</b> |
| <b>11</b> | <b>The Communication Interface.</b> . . . . .      | <b>55</b> |
| 11.1      | Connection of the Interface . . . . .              | 56        |
| 11.1.1    | Jumper Functions . . . . .                         | 57        |
| <b>12</b> | <b>Contact.</b> . . . . .                          | <b>59</b> |

# 1 Explanation of the Symbols Used

To ensure optimum use of this document, note the following explanation of the symbols used.

This symbol indicates an example.



*This symbol indicates a note which, if ignored, will make the procedure or operation more difficult.*



**This symbol indicates a fact which, if not observed, could result in damage to components or represent a danger to persons. Read these passages especially carefully.**





## 2 Foreword

*The Sunny Boy is equipped with the SMA grid guard. This is a type of automatic disconnection device. This means that the Sunny Boy complies with the VDEW (Verband der Elektrizitätswirtschaft – German Electricity Industry Association) regulations for the connection and parallel operation of power-generating systems to the low-voltage grid of the energy supply company and with DIN VDE 0126-1-1, which forms part of these regulations.*



Refer to the operating manual for detailed information on troubleshooting and operating the Sunny Boy.

Sunny Design will assist you in the system design and checking of the string size for a given type of inverter. Further information on Sunny Design is available at [www.SMA.de](http://www.SMA.de).

If you require further information, please call the Sunny Boy Hotline:  
+49 (561) 95 22 - 499

### 2.1 Target Group

#### Warning!

**The Sunny Boy may only be installed by trained specialists. The installer must be approved by the local energy supplier. Read this installation guide carefully. Ensure compliance with all prescribed safety regulations, the technical connection requirements of the local energy supplier and any other applicable provisions.**



This installation guide is exclusively intended for qualified electricians and is intended to assist with the speedy and correct installation and commissioning of the SMA Sunny Boy SB 2100 inverter.

### 2.2 Appropriate Usage

#### Warning!

**The Sunny Boy is designed for operation in grid-connected PV systems. Use of the Sunny Boy in any areas of application other than those specified in this documentation will lead to the loss of the right to all warranty claims and may lead to a fault in the device. This includes, among other things, the operation at voltage sources without any current limit. When in doubt, contact SMA.**







### 3 Safety Instructions

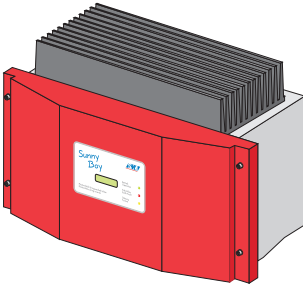

#### Warning! Overvoltage!

Check the system design using the Sunny Design tool ([www.SMA.de](http://www.SMA.de)) or by calling the Sunny Boy Hotline. Overvoltages lead to the destruction of the Sunny Boy.



#### Warning! High voltage!

Work on the Sunny Boy with the cover removed must be carried out by a qualified electrician! High voltages are present in the device. Work is to be carried out on the Sunny Boy only once the AC and DC voltages have been disconnected from the Sunny Boy, and once it has been ensured that the capacitors have been discharged.

The Sunny Boy must be disconnected from the grid and precautions must be taken to prevent the grid being accidentally reconnected. In addition, the connections to the PV generator must be disconnected.

After isolating the AC and DC voltage, you must wait approximately 30 minutes for the capacitors in the Sunny Boy to discharge. Only then is it safe to open the unit by removing the cover and make sure that no voltage is present in the device.



#### Warning! Electrostatic charge!

When working on the Sunny Boy and handling its assemblies, remember to observe all ESD safety regulations. Electronic components are susceptible to electrostatic charge. Discharge any electrostatic charge by touching the grounded housing before handling any electronic component.





# 4 Overview

## 4.1 Unit Description

The following diagram gives a schematic overview of the various components and connection points inside the Sunny Boy with the cover removed:

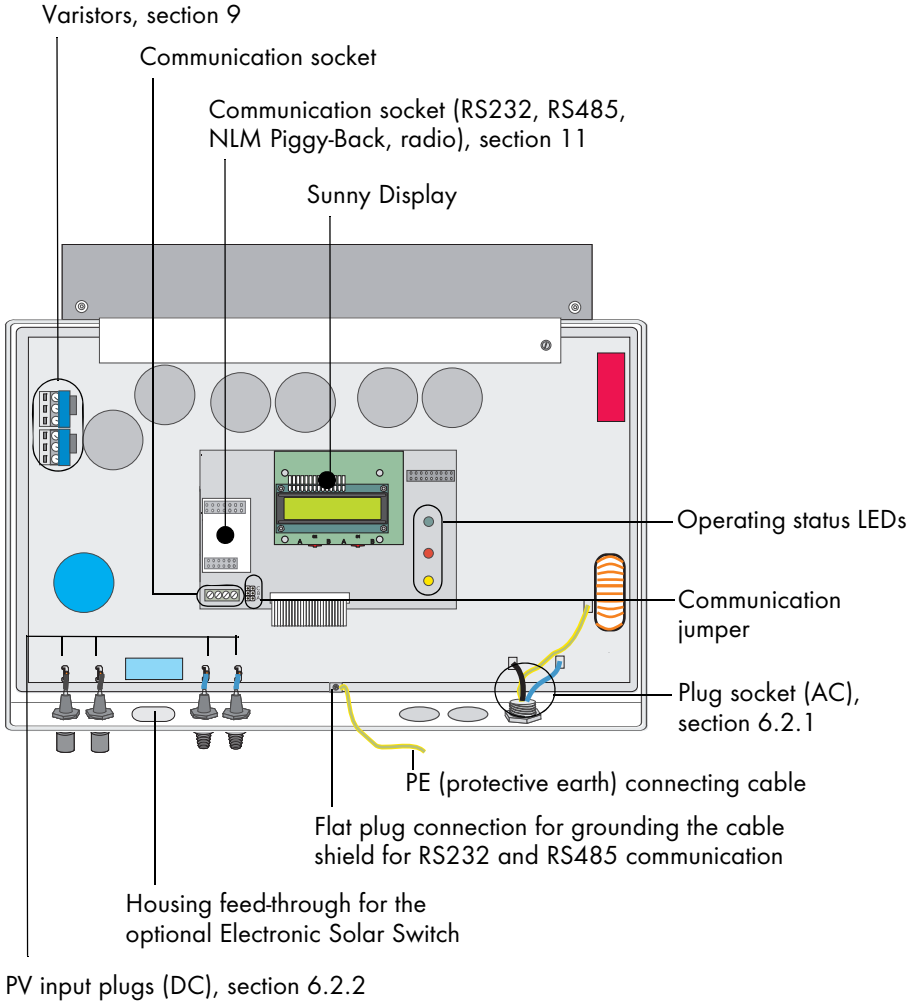

## 4.2 External Dimensions

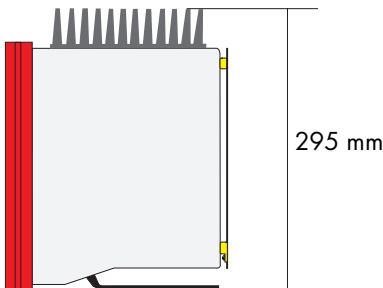
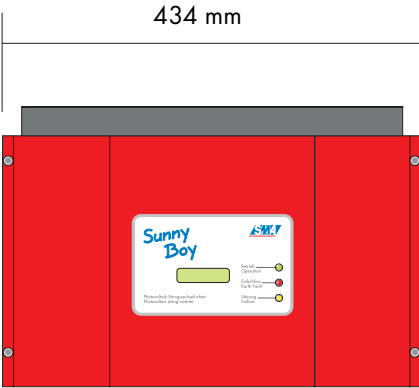
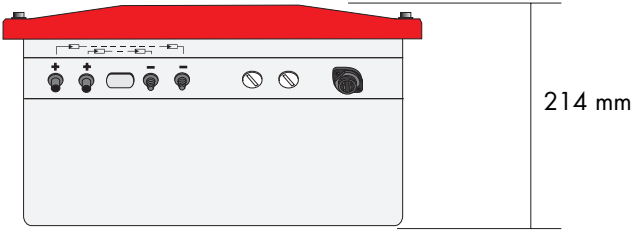

## 5 Installation Requirements

Check that all of the requirements listed below are met before installing and commissioning the Sunny Boy.

### 5.1 Installation Location Requirements

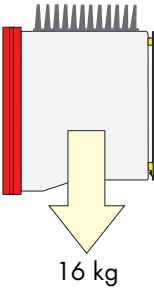

The Sunny Boy SB 2100TL weighs 16 kg. Take this weight into account when choosing the installation location and method of installation.

*The ambient temperature must not be outside the -25 °C to +60 °C range.*



The Sunny Boy should be installed in a place where it is not exposed to direct sunlight. An increased ambient temperature can reduce the yield of the PV system.

The Sunny Boy is designed to be mounted on a vertical wall. However, if absolutely necessary, the Sunny Boy can be installed tilted back at a maximum angle of 45°. Vertical installation at eye-level is preferable for an optimum energy yield and maximum operational comfort. If installing the unit outdoors, make sure that it is not slanting forwards.

We advise against installing the unit in a horizontal position outdoors.

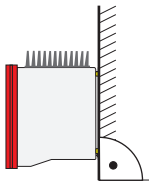

Install the inverter vertically or tilting backward.

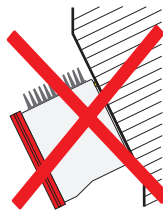
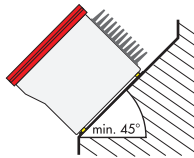

Never install the inverter horizontally or so that it tilts

**When choosing the installation location, be sure to observe the following:**



**Warning! High voltage!**

Unintentionally pulling out the DC plug connectors under load can damage the plugs and could result in personal injury! Install the Sunny Boy in such a way that it is not possible (e.g. for children) to unplug the DC plug connector unintentionally.



**Warning! Risk of burns!**

The temperature of individual parts of the housing, in particular the temperature of the heatsink and the components inside the Sunny Boy can reach more than 60 °C. There is the danger of burn injury when these parts are touched!



**Warning!**

**Do not install the Sunny Boy**

- on flammable construction materials,
- in areas where highly inflammable materials are stored,
- in potentially explosive areas!

When choosing the installation location, ensure there is enough space for heat to dissipate! Under normal conditions, the following recommended values for the space to be kept clear around the Sunny Boy should be followed:

|            | <b>Minimum clearance</b> |
|------------|--------------------------|
| Sides      | 20 cm                    |
| Top        | 20 cm                    |
| Underneath | 20 cm                    |
| Front      | 5 cm                     |

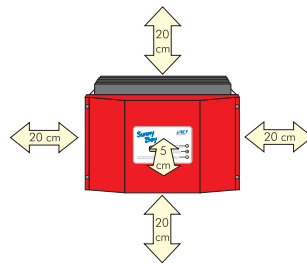

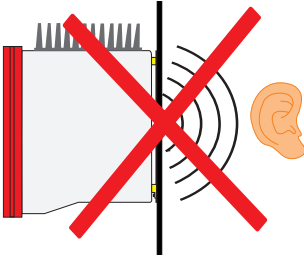

In a living area, the unit should not be mounted on plasterboard walls or alike as otherwise audible vibrations are likely to result.

We recommend securing the unit to a solid surface. The Sunny Boy can make noises when in use which can be seen as a nuisance when installed in a living area.

## 5.2 PV Generator Requirements

The Sunny Boy is designed to be connected to up to two strings (PV modules wired in series) having a homogenous structure (modules of the same type, identical orientation and tilt).

Sunny Design will assist you in the system design and checking of the string size for a given type of inverter. Further information on Sunny Design is available at [www.SMA.de](http://www.SMA.de).

The unit has four DC plug connectors (two for each string) for connecting the PV generators. The connecting cables from the PV generators must also be fitted with this type of plug connector. A pre-assembled set for connecting the free cable ends from a string is available as an optional accessory. The SMA order codes for the various connectors are as follows:

- Multi-Contact 3 mm: SWR-MC
- Multi-Contact 4 mm: MC-SET
- Tyco: TYCO-SET

| Limit values for DC input |            |
|---------------------------|------------|
| Max. voltage              | 600 V (DC) |
| Max. input current        | 11 A (DC)  |

## 5.3 Low Voltage Grid (AC)

The Sunny Boy must have a three-conductor connection to the grid (live (L), neutral (N), protective earth (PE)).

The grid connection terminals on the AC connection socket included in the accessories kit can take wires with a cross-section of up to 2.5 mm<sup>2</sup>. The accessories kit also contains a PG13.5 AC connection socket for connecting cables with a cable diameter between 9 mm and 13.5 mm, while the PG16 connection socket is used for cables with cable diameters from 13.5 mm up to a maximum of 17 mm. For detailed instructions, see sections "Connecting the AC Output with PG13.5" (Page 26) and "Connecting the AC Output with PG16" (Page 28).

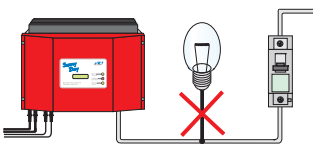
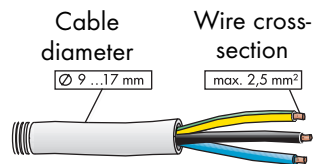

### Warning!

**We recommend using a 16 A line circuit breaker to protect the power circuit. No loads should be connected to this power circuit.**





## Rating for a Line Circuit Breaker in a Photovoltaic Power Generating System Operated in Parallel to the Low Voltage Grid

Various factors should be taken into account when selecting line circuit breakers. These include, for example:

- The type of cable used (conductor material and insulation)
- Ambient temperatures affect the cables (higher temperatures result in a reduced maximum current load)
- Method of routing the cable (reduces the maximum current load)
- Bundling cables together (reduces the maximum current load)
- Loop impedance  $[Z]$  (in the event of a body contact this limits the current that can flow and therefore determines the response behavior of the circuit breaker)
- Sufficient distance between the circuit breakers so as to avoid undue heating (heat can trigger the circuit breaker early)
- Selectivity
- Protection class of the connected load (VDE 0100, part 410, "Protection against electric shock")



*Please pay attention to section 10 "Rating for a Line Circuit Breaker" (Page 51).*

The following standards should be followed in all cases:

- DIN VDE 0298-4 (Cable routing and current-carrying capacity)
- DIN VDE 0100, part 430 (Protective measures; protection of cable and cords against overcurrent)
- DIN VDE 0100, part 410 (Protective measures; protection against electric shock)

AC cable system impedance should not exceed 1 Ohm. This is necessary, amongst other things, for the correct operation of the impedance monitoring. In addition, we recommend dimensioning the cable cross-section so that output losses do not exceed 1 % at nominal power. Output losses depending on the cable length and cross-section are shown in the graph below. Multi-wire cables with copper forward and return conductors are used.

### Output Losses of the Sunny Boy SB 2100TL

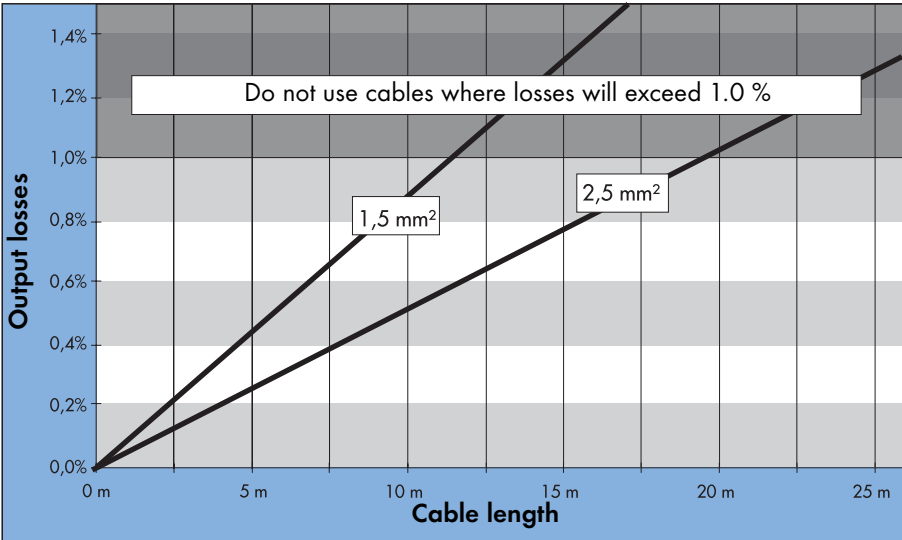

The maximum cable lengths for the different cable cross-sections are as follows:

| Cable cross-section | 1.5 mm <sup>2</sup> | 2.5 mm <sup>2</sup> |
|---------------------|---------------------|---------------------|
| Max. length         | 11 m                | 18 m                |

The Sunny Boy is designed for operation on 220 -240 V grids at a grid frequency of 50 Hz. When connecting an inverter to the public grid, follow the connection requirements of the local grid operator.

|   | <b>Limit values for AC output</b> |
|---|-----------------------------------|
| Voltage range (complying with DIN VDE 0126-1-1)   | 198 V ... 253 V                   |
| Frequency range (complying with DIN VDE 0126-1-1) | 47.55 Hz ... 50.2 Hz              |
| Voltage range<br>(extended operating range)       | 180 V ... 260 V                   |
| Frequency range<br>(extended operating range)     | 45.5 Hz ... 54.5 Hz               |

DIN VDE 0126-1-1 only applies in Germany.



## 6 Installation

### 6.1 Mounting the Device

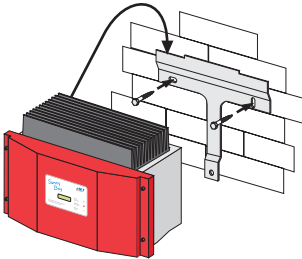

To make the job easier, we recommend you use the supplied wall bracket to mount the Sunny Boy. For vertical installation on solid concrete or block walls, for example, you can fit the bracket using 6 mm x 50 mm hexagon bolts to DIN 571 standard, stainless steel type, and with wall plugs type SX8.

When selecting the mounting materials, be sure to take into account the weight of the Sunny Boy (approx. 16 kg).

If you do not want to use the supplied wall bracket as a template, observe the dimensions shown in the illustration below. The procedure for mounting the inverter using the wall bracket is described on the following pages.

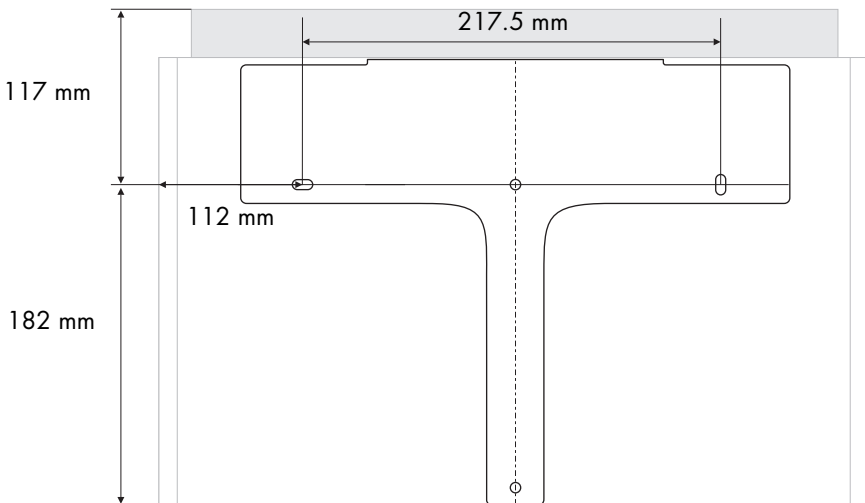

1. Mount the wall bracket (1). To mark the positions to drill the holes, you can use the wall bracket as a drilling template.
2. Now hang the Sunny Boy onto the wall bracket (2) using its upper mounting plate so that it cannot be moved sideways.
3. Secure the Sunny Boy in position by screwing the supplied M6x10 bolt into the central threaded hole at the bottom of the bracket (3).
4. Make sure that the Sunny Boy is positioned securely on the bracket.

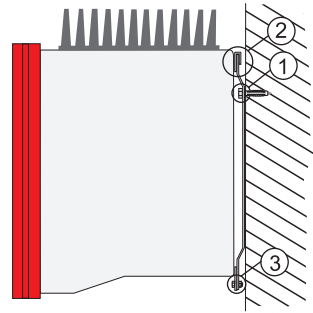

## 6.2 Electrical Installation



### Warning!

**Make sure to check the polarity of the strings before connecting them!**

The complete wiring for a Sunny Boy is shown schematically in the following figure:

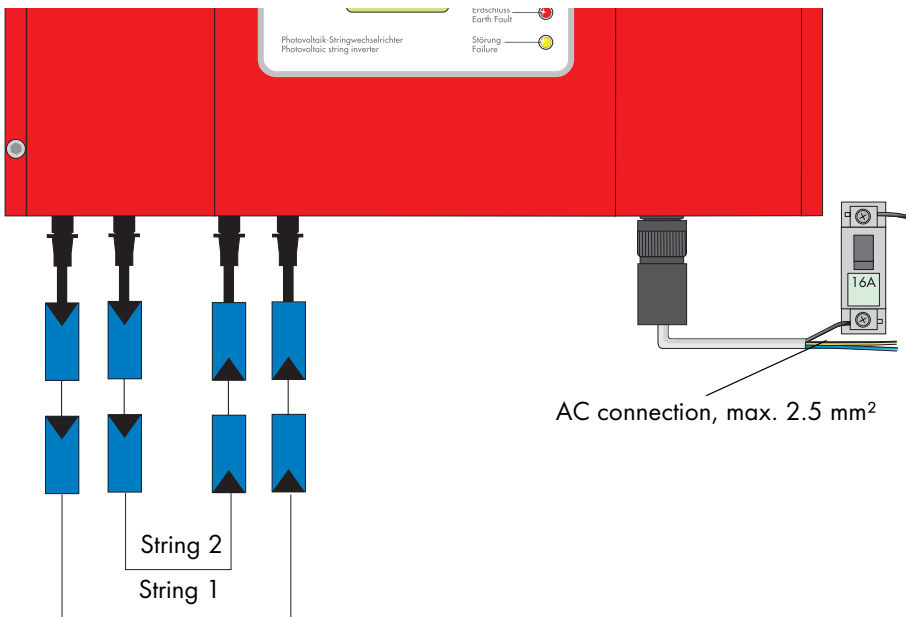

### View from below

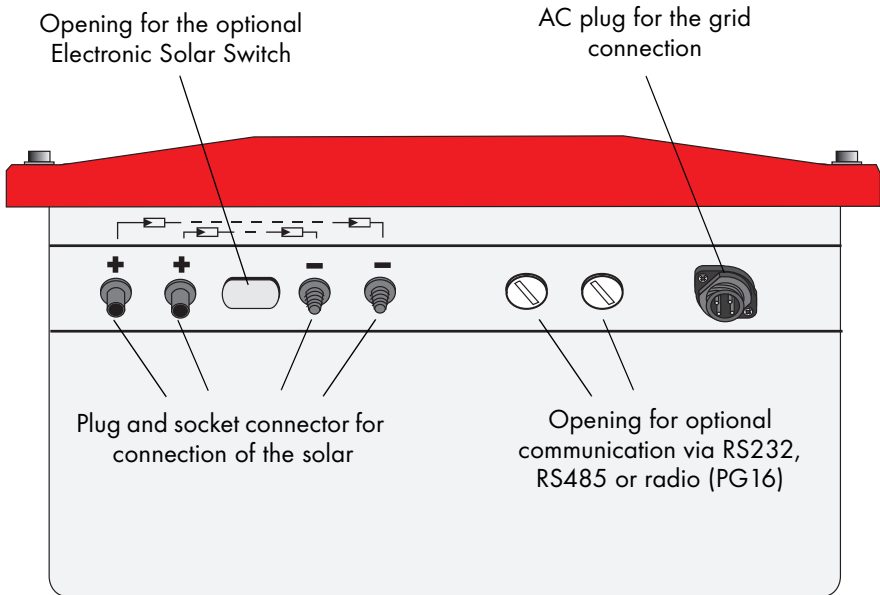

## 6.2.1 Connecting the AC Output



### Warning! Voltage!

Before you connect the grid connection cable to the AC connection socket, make sure that no voltage is present in the cable.

A round plug connector system is used, which allows various cable diameters to be used in the cable outlet. For this reason, the accessories kit includes a PG13.5 pressure screw and a PG16 pressure screw. Check which screw fitting is the right one for your AC cable.

To connect up the AC output, follow these steps:

1. Check the grid voltage. If this is higher than 253 V, the Sunny Boy will not be fully operational. In this case, contact the local grid operator for assistance.
2. Isolate the grid connection (switch the line circuit breaker to its "off" position), make sure it cannot be switched back on, and test to make sure no voltage is present.

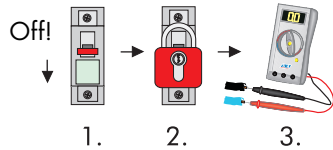

3. Peel off approximately 30 mm of the cable jacket. Shorten L and N to 25 mm.

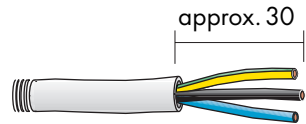

4. Strip approximately 4 mm of the three wires.

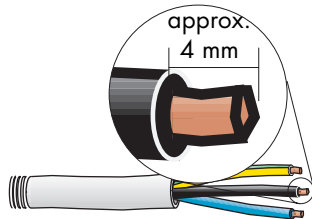



5. Now take the AC connection socket parts from the accessories kit and connect up the cable, with shielding and insulation stripped, as described on the following pages.

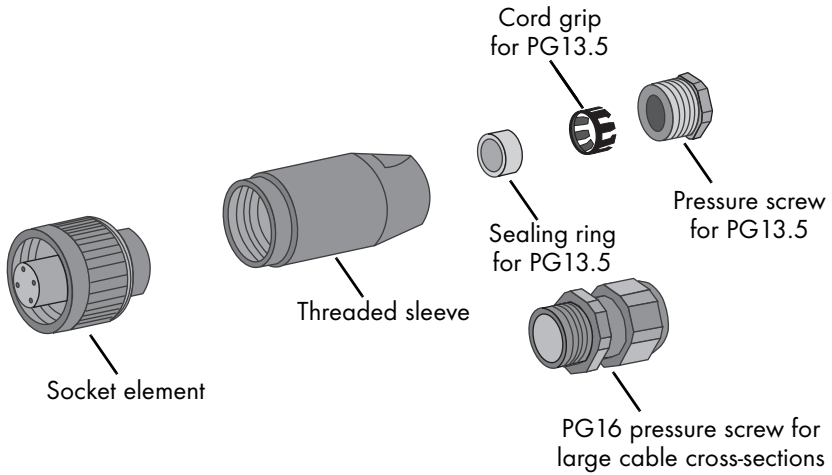

## Connecting the AC Output with PG13.5

To connect a cable with a maximum cross-section of 13.5 mm<sup>2</sup>, proceed as follows.

1. Press the sealing ring (1) into the cord grip (2).

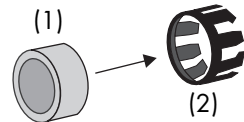

2. Now slide the pressure screw (3) over the cable first of all, followed by the cord grip with the sealing ring (4) in it. Now slide the threaded sleeve (5) over the cable.

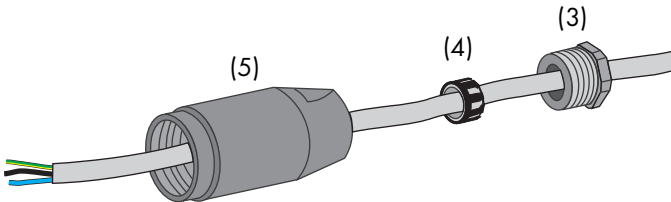

3. Now connect the individual conductors to the socket element in sequence.

- Protective earth PE (green/yellow) to the screw terminal with the earth sign.
- Neutral conductor N (blue) to screw terminal 1.
- Live L (brown or black) to screw terminal 2.
- Terminal 3 remains unused.

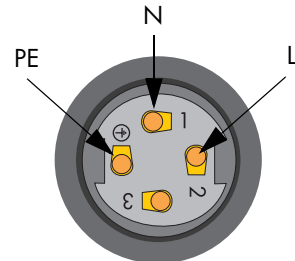

4. Make sure the wires (6) are securely connected.

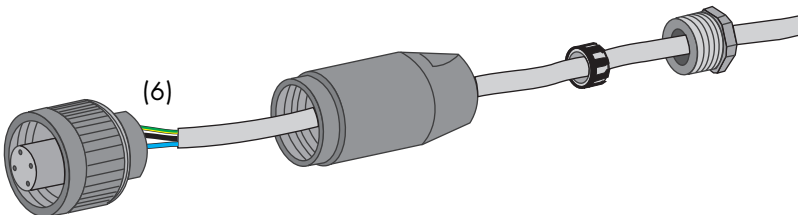

5. Now screw the threaded sleeve (7) onto the socket element (8) and tighten it.

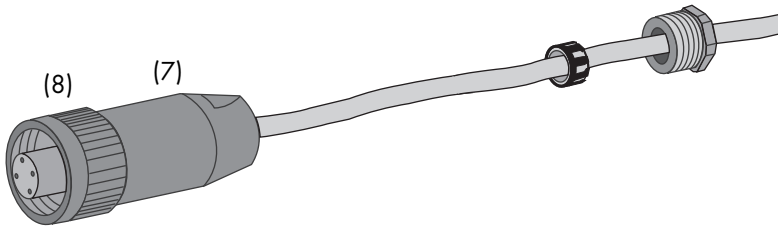

6. Now screw the pressure screw (9) into the threaded sleeve (10) and tighten it. The cord grip with the sealing ring is pressed into the threaded sleeve and can no longer be seen.

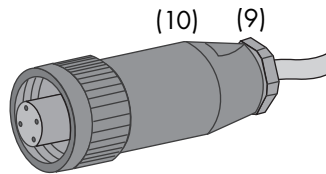

The AC connection socket is now fully assembled.

If you are not going to connect up the Sunny Boy immediately, close the socket element using the cap supplied in the accessories kit.

If the Sunny Boy is already installed, you can now connect up the fully assembled AC connection socket to the flange plug on the Sunny Boy. To do this, remove the protective cap from the flange plug on the Sunny Boy. Firmly tighten the threaded ring on the AC connection socket to the flange plug to seal the connection and secure it.

### Warning!

**Do not switch the line circuit breaker on yet! The Sunny Boy may only be connected to the AC grid once the PV strings are connected and the device is securely closed.**



## Connecting the AC Output with PG16

To connect a cable with a cross-section between 13.5 mm<sup>2</sup> and 16 mm<sup>2</sup>, proceed as follows.

1. First of all, slide the pressure screw with the PG16 screw fitting (1) onto the cable. Now slide the threaded sleeve (2) over the cable.

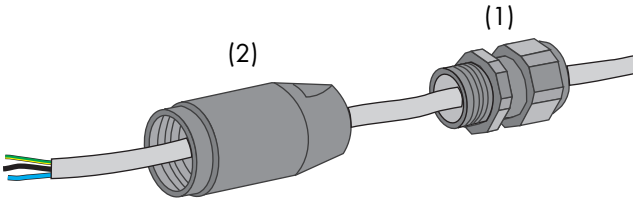

2. Now connect the individual conductors to the socket element in sequence.

- Protective earth PE (green/yellow) to the screw terminal with the earth sign.
- Neutral conductor N (blue) to screw terminal 1.
- Live L (brown or black) to screw terminal 2.
- Terminal 3 remains unused.

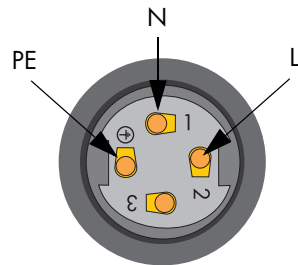

3. Make sure the wires (3) are securely connected.

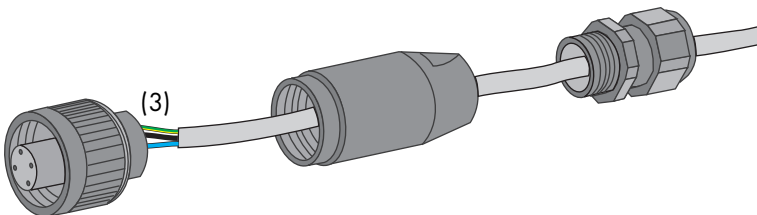

4. Now screw the threaded sleeve (4) onto the socket element (5) and tighten it.

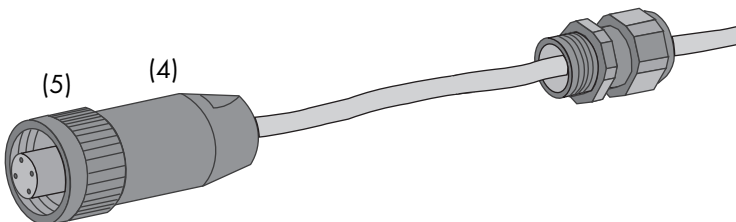

5. Now screw the pressure screw (6) into the threaded sleeve (7) and tighten it.
6. Firmly tighten the screw fitting against the seal and strain relief.

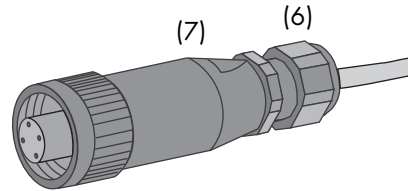

The AC connection socket is now fully assembled.

If you are not going to connect up the Sunny Boy immediately, close the socket element using the cap supplied in the accessories kit.

If the Sunny Boy is already installed, you can now connect up the fully assembled AC connection socket to the flange plug on the Sunny Boy. To do this, remove the protective cap from the flange plug on the Sunny Boy. Firmly tighten the threaded ring on the AC connection socket to the flange plug to seal the connection and secure it.

### Warning!

**Do not switch the line circuit breaker on yet! The Sunny Boy may only be connected to the AC grid once the PV strings are connected and the device is securely closed.**



## 6.2.2 PV String (DC) Connection

To connect up the input, follow these steps:

1. Make sure the PV generator connectors have the right polarity and do not exceed the maximum string voltage. See also section 5.2 "PV Generator Requirements" (Page 16).

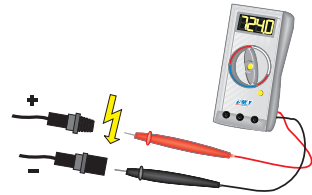

### Warning!

**Dangerously high voltages may be present. Danger of death!**

2. Taking one DC plug connector at a time, measure the direct current voltage between one DC plug connector of a string and ground potential.
3. If the measured voltages are constant and their total is roughly the same as the open circuit voltage of the string, then there is a ground fault in this string. Its approximate location can be deduced from the relationships between the voltages.

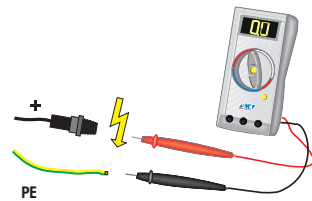

### Warning!

**Do not connect strings to the Sunny Boy that contain a ground fault until you have fixed the ground fault in the PV generator!**

4. Repeat points 2 and 3 for each string.
5. Connect up the faultless PV generator strings to the inverter.
6. Close the unused DC input sockets with the caps included in the delivery.

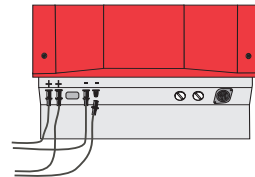

## 6.3 Commissioning

You can commission the Sunny Boy when:

- the housing cover is securely screwed shut,
- the DC cables (PV strings) are fully connected and the unused DC plug connectors on the bottom of the housing are closed using the protective caps.
- the AC (grid) cable is connected correctly.

### How to Commission the Inverter

1. First of all, switch the line circuit breaker to the "on" position.

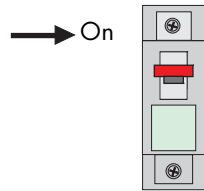

2. Now look at the LED display and consult the table on the following page to check whether the Sunny Boy is in a fault-free and expedient operating mode. If this is the case, commissioning was successfully completed.

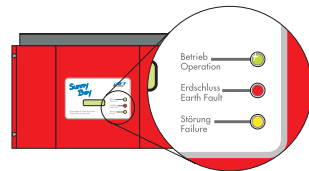

### Warning!

**If the bottom yellow LED flashes four times at intervals of one second, the grid voltage and the PV generator must be immediately disconnected from the Sunny Boy! There is a risk of damage to the inverter resulting from excessive DC input voltage!**



Check the string voltages again to make sure they are within the limits stated in section 5.2 "PV Generator Requirements" (Page 16). If the input voltage is too high, contact the planner / installer of the PV generator for assistance.

If despite checking the string voltages the LED signal occurs again when the PV generator is connected to the Sunny Boy, disconnect the PV generator from the Sunny Boy again and contact **SMA Technologie AG** (see section 12 "Contact" (Page 59)).

| Green                                     | Red                 | Yellow              | Status                        |
|---|---------------------|---------------------|-------------------------------|
| shines continuously                       | is not shining      | is not shining      | OK (working mode)             |
|   | shines continuously | is not shining      | failure                       |
|   |                     | shines continuously | OK (initialization)           |
| flashes quickly (3 x per second)          | is not shining      | is not shining      | OK (stop)                     |
|   | shines continuously | is not shining      | failure                       |
| flashes slowly (1 x per second)           | is not shining      | is not shining      | OK (waiting, grid monitoring) |
|   | shines continuously | is not shining      | failure                       |
| briefly goes out (approx. 1 x per second) | is not shining      | is not shining      | OK (derating)                 |
|   | shines continuously | is not shining      | failure                       |
| is not shining                            | is not shining      | is not shining      | OK (night shutdown)           |
|   |                     | shining/flashing    | failure                       |
|   | shines continuously | is not shining      | failure                       |
|   |                     | shining/flashing    | failure                       |

For a detailed description of the fault messages and their causes, see the operating manual.



## 7 Opening and Closing the Sunny Boy

### Warning!

If you need to open the device for whatever reason, pay attention to section 3 "Safety Instructions" (Page 9).



### 7.1 Opening the Sunny Boy

#### Warning!

Follow the sequence below under all circumstances!



1. Switch the line circuit breaker to the "off" position.
2. Disconnect the PV generator from the Sunny Boy.
3. Wait 30 minutes!
4. Remove the four screws from the housing cover and pull the cover forward smoothly. Remove the PE connection from the cover. Loosen the locking on the PE connectors on the cover when you remove them.

### 7.2 Closing the Sunny Boy

#### Warning!

Follow the sequence below under all circumstances!



1. Reconnect the protective earth (PE) to the housing cover. Now secure the housing cover of the Sunny Boy by evenly tightening the four screws.
2. Connect the PV generator.
3. Switch the line circuit breaker to the "on" position.
4. Now check whether the LED display on the Sunny Boy indicates that the device is functioning correctly.



## 8 Technical Data

### 8.1 PV Generator Connection Data

| Description                            | Abbr.         | Setting   |
|--|---------------|---|
| Max. input voltage                     | $DC_{max}$    | 600 V <sup>a)</sup>                                       |
| Input voltage, MPP range               | $U_{PV}$      | 125 V ... 600 V   |
| Max. input current                     | $I_{PV, max}$ | 11 A  |
| Max. input power                       | $P_{DC}$      | 2200 W  |
| All-pole isolator on the DC input side |               | DC plug connector (ESS optional)                          |
| Overvoltage protection                 |               | thermally monitored varistors                             |
| Voltage ripple                         | $U_{pp}$      | < 10 % of the input voltage                               |
| Insulation protection                  |               | ground fault monitoring ( $R_{iso} > 1 \text{ M}\Omega$ ) |
| Operating consumption                  |               | < 7 W (standby)   |
| Reverse polarity protection            |               | via short-circuit diode                                   |

- a) Ensure that the maximum input open circuit voltage, which can occur at a cell temperature of -10 °C, does not exceed the maximum input voltage.

## 8.2 Grid Connection Data

| Description  | Abbr.         | Setting  |
|--|---------------|--|
| Nominal output power   | $P_{ACnom}$   | 1950 W   |
| Peak output power  | $P_{AC, max}$ | 2100 W   |
| Nominal output current   | $I_{ACnom}$   | 8.5 A  |
| Harmonic distortion of output current (at $K_{Ugrid} < 2\%$ , $P_{AC} > 0.5 P_{ACnom}$ ) | $K_{IAC}$     | < 4 %  |
| Short-circuit proofing   |               | grid-side via current regulation   |
| Operating range, grid voltage  | $U_{AC}$      | 180 ... 260 V AC<br>Germany: 198 ... 253 V AC                            |
| Operating range, grid frequency  | $f_{AC}$      | 45.5 ... 54.5 Hz<br>Germany: 47.55 ... 50.2 Hz                           |
| All-pole isolator on grid side   |               | automatic disconnection device (SMA grid guard 2), double implementation |
| Power factor (based on the current's fundamental frequency)                              | cos phi       | 1 (at nominal power output)  |
| Overvoltage category   |               | III  |
| Test voltage (DC)  |               | 2.2 kV (1 s routine testing / 5 s type testing)                          |
| Test surge voltage   |               | 4 kV (serial interface: 6 kV)  |
| Operating consumption in night mode  |               | 0.1 W  |

## 8.3 General Data

| General data                     |                                       |
|----------------------------------|---------------------------------------|
| Protection degree (DIN EN 60529) | IP65                                  |
| Dimensions (w x h x d)           | 434 mm x 295 mm x 214 mm<br>(approx.) |
| Weight                           | approx. 16 kg                         |

| Climatic conditions (DIN EN 50178:1998-04): |  |
|---|--|
| Location of type C:                         | Class 4K4H<br>Extended humidity range:<br>0 ... 100 %<br>Extended temperature range:<br>-25 °C to +60 °C |
| Transport of type E:                        | Class 2K3<br>Temperature range:<br>-25 °C to +70 °C  |
| Max. operating altitude                     | 3000 m above sea level   |

| External interfaces                        |   |
|--|---|
| Data transmission over mains power line    | optional  |
| Data transmission over separate data cable | optional, RS232 / RS485,<br>galvanically isolated |
| Wireless data transmission                 | optional  |

## 8.4 Efficiency

| Efficiency                   |               |        |
|------------------------------|---------------|--------|
| Max. efficiency              | $\eta_{max}$  | 96 %   |
| European standard efficiency | $\eta_{euro}$ | 95.2 % |

The efficiency of the Sunny Boy depends mainly on the input voltage of the connected PV strings. The higher the input voltage, the higher the efficiency.

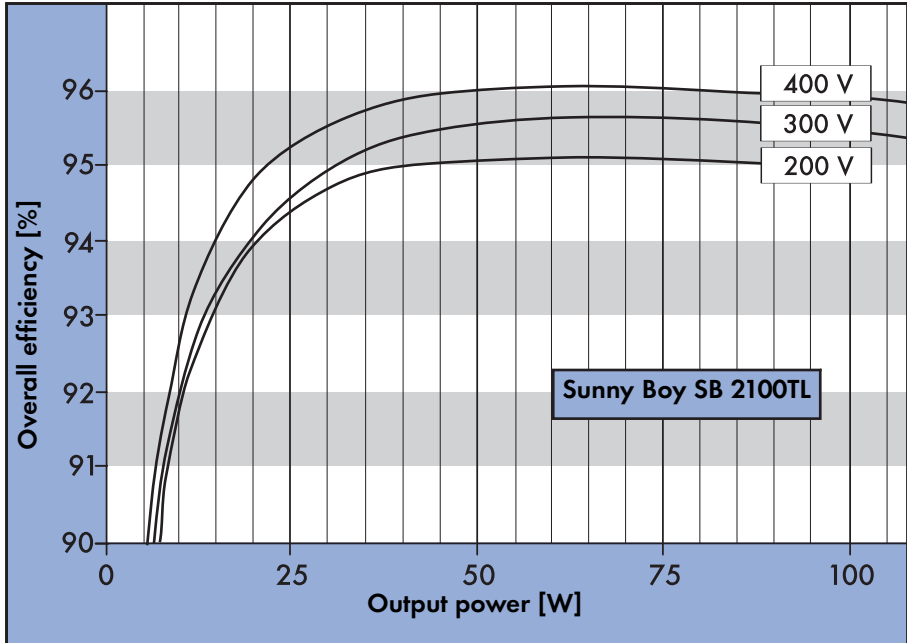

## 8.5 Operating Parameters

### 8.5.1 Explanation of the Operating Parameters

| Name        | Explanation  |
|-------------|--|
| Betriebsart | Operating mode of the Sunny Boy:<br>MPP: Maximum Power Point.<br>Konstantspg.: constant voltage mode (nominal voltage is defined in "Usoll-Konst").<br>Stop: disconnection from grid, no operation.  |
| Default     | Used for setting country-specific information.<br>GER/ENS: Landesspezifische Parametereinstellungen für Deutschland nach der DIN VDE 0126 (4.99)<br>GER/VDE0126-1-1: country-specific parameter settings for Germany in accordance with DIN VDE 0126-1-1.<br>AUS: country-specific parameter settings for Australia.<br>GB: country-specific parameter settings for Great Britain. |
| dFac-Max    | Maximum "grid frequency change" before the grid monitoring system disconnects the device from the grid.  |
| dZac-Max    | Maximum "grid impedance change" before the grid monitoring system disconnects the device from the grid.  |
| E_Total     | Total energy yield for the inverter. This change may be necessary when you exchange your Sunny Boy and want to use the data from the old device.   |
| Fac-delta-  | Maximum frequency, above (Fac-delta+) and below (Fac-delta-) the grid frequency of 50 Hz, before the grid monitoring system disconnects the device from the grid.  |
| Fac-delta+  |  |
| h_Total     | Total hours of operation for the inverter. This change may be necessary when you exchange your Sunny Boy and want to use the data from the old device.   |
| Ni-Test     | Setting the impulse for impedance monitoring. This parameter only functions when the Sunny Boy is deactivated (disconnected on the AC side) or in "Stop" mode.   |
| Inst.-Code  | Parameters for stand-alone grid recognition can only be changed after entering the SMA grid guard password.  |
| Plimit      | Upper limit for AC output power.   |
| SMA-SN      | Serial number of the Sunny Boy.  |

| Name             | Explanation  |
|------------------|--|
| Software-BFR     | Firmware version of the operation control unit (BFR).  |
| Software-SRR     | Firmware version of the current control unit (SRR).  |
| Speicherfunkt.   | <p>Default Parameter: returns all parameters to the factory settings.</p> <p>Reset Betriebsdaten: returns all user level parameters to the factory settings.</p> <p>Reset Fehler: resets a permanent error.</p>  |
| Speicher/Storage | <p>Permanent: modified parameters are stored in the EEPROM and can be used even when the Sunny Boy has been restarted.</p> <p>Volatil: prevents the parameters being stored in the EEPROM, the parameters are only stored until the next restart.</p>  |
| T-Start          | The period the Sunny Boy waits after the Upv-Start value has been reached.   |
| T-Stop           | The period the Sunny Boy waits before disconnecting from the grid when Pac drops below the set value.  |
| Uac-Min          | Lower (Uac-Min) and upper (Uac-Max) limits of the allowable AC voltage (stand-alone grid recognition), before the grid monitoring system disconnects the device from the grid.   |
| Uac-Max          |  |
| Upv-Start        | <p>The DC voltage required before the inverter begins feeding power into the grid.</p> <p>This value is above the minimum MPP voltage which is required in order to always guarantee safe connection to the grid, and to minimize grid relay wear.</p> <p>If, after disconnection from the grid, and in the absence of any further faults, the inverter does not automatically reconnect to the grid, this parameter can be decreased in small steps.</p> <p>It must be noted, that if the value is set too low, this leads to an increased number of connections to the grid, and thus to increased wear of components.</p> |
| Usoll-Konst      | PV desired voltage for constant operational voltage. This parameter is only important when the "Betriebsart" parameter is set to U-konst.  |



## 8.5.2 Parameter Settings for Germany

### Warning!

Unauthorized changes to the operating parameters may result in:

- injury or accidents as a result of changing the internal safety routines in the Sunny Boy,
- voiding the Sunny Boy's operating approval certificate,
- voiding the Sunny Boy's warranty.



Never change the parameters of your Sunny Boy without express authorization and instructions.

Grayed-out parameters are only displayed in installer mode. The table below contains the parameters that are applicable in Germany.

| Name                 | Short descr. | Value range   | Factory setting  |
|----------------------|--------------|---|------------------|
| Betriebsart          |              | MPP,<br>Konstantspg.,<br>Stop                       | MPP              |
| Default *            |              | GER/VDE0126-1-1, GER/ENS, AUS, GB, USA              | GER/VDE 0126-1-1 |
| dFac-Max *           | Hz/s         | 0,005 ... 4,0                                       | 4                |
| dZac-Max *           | mOhm         | 0 ... 2000  | 600              |
| E_Total              | kWh          | 0 ... 200000  |                  |
| Fac-delta- *         | Hz           | 0 ... 4,5   | 2,45             |
| Fac-delta+ *         | Hz           | 0 ... 4,5   | 0,19             |
| h_Total              | h            | 0 ... 200000  |                  |
| Inst.-Code           |              |   |                  |
| NiTest *             |              | 0/1   | 1                |
| Speicherfunkt.       |              | Default Param.,<br>Reset Betrdaten,<br>Reset Fehler | none             |
| Speicher/<br>Storage |              | permanent,<br>volatil                               | permanent        |
| T-Start *            | s            | 5 ... 300   | 10               |
| T-Stop               | s            | 1 ... 300   | 10               |

| Name        | Short descr. | Value range | Factory setting |
|-------------|--------------|-------------|-----------------|
| Uac-Min *   | V            | 180 ... 300 | 198             |
| Uac-Max *   | V            | 180 ... 300 | 253             |
| Upv-Start   | V            | 125 ... 600 | 150             |
| Usoll-Konst | V            | 125 ... 600 | 410             |



*Parameters designated with \* are safety-related grid monitoring parameters. To change the SMA grid guard parameters, you must enter your personal SMA grid guard password (Inst.-Code). Call the Sunny Boy Hotline to obtain your personal SMA grid guard password.*

### 8.5.3 Fixed Parameters

The following parameters are displayed in the parameter list but cannot be changed:

| <b>Name</b>  | <b>Short descr.</b> | <b>Factory setting</b> |
|--------------|---------------------|------------------------|
| Plimit       | W                   | 2100                   |
| SMA-SN       |                     |                        |
| Software-BFR |                     |                        |
| Software-SRR |                     |                        |

## 8.6 Certificates

### 8.6.1 CE Declaration of Conformity

#### EC Declaration of Conformity in terms of the Guidelines of the European Community



- Electromagnetic Compliance 2004/108/EC
- Low Voltage Regulation 2006/95/EC

The devices stated below have been developed, constructed and manufactured according to the above mentioned EC directives. The applied harmonized standards are shown in the following table.

|                                 | Sunny Boy   | Sunny Mini Central   | Sunny Boy  |
|---------------------------------|---|--|--|
|                                 | SB 700, SB 1100, SB 1100LV, SB 1700, SB 2100TL, SB 2500, SB 2800i, SB 3000, SB 3300TL, SB 3300TL HC | SMC 5000, SMC 5000A, SMC 6000, SMC 6000A, SMC 6000TL, SMC 7000TL, SMC 7000HV, SMC 8000TL | SB 3300, SB 3800, SB 4000TL-20, SB 4200TL Multi-String, SB 4200TL HC Multi-String, SB 5000TL Multi-String, SB 5000TL HC Multi-String, SB 5000TL-20 |
| <b>Emission:</b>                |   |  |  |
| DIN EN 61000-6-3: 2002-08       | x   |  | x  |
| DIN EN 61000-6-4: 2002-08       | x   |  | x  |
| DIN EN 55022: 2003-09, Class B  | x   |  | x  |
| <b>Utility Interference:</b>    |   |  |  |
| DIN EN 61000-3-3: 2002-05       | x   |  | x  |
| DIN EN 61000-3-2: 2001-12       | x   |  |  |
| DIN EN 61000-3-12: 2004-06      |   |  | x  |
| <b>Immunity:</b>                |   |  |  |
| DIN EN 61000-6-1: 2002-08       | x   |  | x  |
| DIN EN 61000-6-2: 2002-08       | x   |  | x  |
| <b>Safety:</b>                  |   |  |  |
| DIN EN 50178: 1998-04           | x   |  | x  |
| <b>Semiconductor-Converter:</b> |   |  |  |
| DIN EN 60146-1-1: 1994-03       | x   |  | x  |

Note:  
This declaration of conformity is not valid any longer,  
\* if the product is modified, supplemented or changed in any other way,  
\* components, which are not part of the SMA accessories kit, are integrated in the product, as well as in case the product is used or installed improperly.

SMA Technologie AG  
Hannoversche Strasse 1-5  
34266 Niestetal, Germany  
Tel. +49 561 9522-0  
Fax +49 561 9522-100  
info@SMA.de  
www.SMA.de

Niestetal, 21.09.2007  
SMA Technologie AG

*i. V. Frank Greizer*

i.V. Frank Greizer  
(Head of Development  
Solar Technology)

CE\_SBS/SMC-11/BE/407



# Declaration of Conformity

according to the VDEW guideline for utility interactive inverters

| Inverter type                     | Nominal apparent power $S_N$ | Max. apparent power $S_{max10Min}$ | $S_{max10Min} / S_N$ |
|-----------------------------------|------------------------------|------------------------------------|----------------------|
| Sunny Boy SB 700                  | 460, 600, 700 VA             | 460, 600, 700 VA                   | 100 %                |
| Sunny Boy SB 1100                 | 1000 VA                      | 1100 VA                            | 110 %                |
| Sunny Boy SB 1100LV               | 1000 VA                      | 1100 VA                            | 110 %                |
| Sunny Boy SB 1700                 | 1550 VA                      | 1700 VA                            | 110 %                |
| Sunny Boy SB 2100TL               | 1950 VA                      | 2100 VA                            | 108 %                |
| Sunny Boy SB 2500                 | 2300 VA                      | 2500 VA                            | 109 %                |
| Sunny Boy SB 2800i                | 2600 VA                      | 2800 VA                            | 108 %                |
| Sunny Boy SB 3000                 | 2750 VA                      | 3000 VA                            | 109 %                |
| Sunny Boy SB 3300TL HC            | 3000 VA                      | 3300 VA                            | 110 %                |
| Sunny Boy SB 3300                 | 3300 VA                      | 3600 VA                            | 109 %                |
| Sunny Boy SB 3800                 | 3800 VA                      | 3800 VA                            | 100 %                |
| Sunny Boy SB 4000TL20             | 4000 VA                      | 4000 VA                            | 100 %                |
| Sunny Boy SB 4200TL HC M5         | 4000 VA                      | 4200 VA                            | 105 %                |
| Sunny Boy SB 5000TL HC M5         | 4600 VA                      | 5000 VA                            | 109 %                |
| Sunny Boy SB 5000TL20             | 4600 VA                      | 5060 VA                            | 110 %                |
| Sunny Mini Central SMC 5000A      | 5000 VA                      | 5500 VA                            | 110 %                |
| Sunny Mini Central SMC 6000A      | 6000 VA                      | 6000 VA                            | 100 %                |
| Sunny Mini Central SMC 7000HV     | 6650 VA                      | 7000 VA                            | 105 %                |
| Sunny Mini Central SMC 6000TL     | 6000 VA                      | 6000 VA                            | 100 %                |
| Sunny Mini Central SMC 7000TL     | 7000 VA                      | 7000 VA                            | 100 %                |
| Sunny Mini Central SMC 8000TL     | 8000 VA                      | 8000 VA                            | 100 %                |
| Sunny Mini Central SMC 9000TL-10  | 9000 VA                      | 9000 VA                            | 100 %                |
| Sunny Mini Central SMC 10000TL-10 | 10000 VA                     | 10000 VA                           | 100 %                |
| Sunny Mini Central SMC 11000TL-10 | 11000 VA                     | 11000 VA                           | 100 %                |

We hereby declare that the devices listed above meet the stipulations applicable to inverters in VDEW guidelines for the connection and parallel operation of electrical power units in a low-voltage grid. In particular, the 'SMA grid guard', an independent disconnection device, is integrated into all listed inverters and carries out all the functions of a 'Mains monitoring device with allocated switching devices in series (MSD)', in accordance with DIN VDE 0126-1-1. A test certificate (clean report of findings) from the testing and certification department of the BG-PrüfZert is available for this. As a result, the devices described above are clearly marked with

“VDE 0126-1-1 (2.06)”

Furthermore, the devices listed above also meet VDN (Association of German network operators, affiliated to the VDEW) stipulations in terms of the ratios between maximum apparent output (average over 10 minutes) and nominal apparent output, in accordance with the 'notes on VDEW guidelines' (March 2004). As a result, the devices described above fulfil all the conditions for utility interactive operation with the public low-voltage grid.

Niestetal, 7.1.2008

**SMA Technologie AG**

*i. V. Frank Greizer*

i.V. Frank Greizer

(Head of Development Solar Technology)

**SMA Technologie AG**

Hannoversche Strasse 1-5  
34266 Niestetal  
Tel. +49 561 9522 - 0  
Fax +49 561 9522 - 100  
www.SMA.de  
info@SMA.de



SB-NENN24;BED 08

## 8.6.2 SMA Grid Guard Certificate

The Sunny Boy is equipped with the automatic disconnection device SMA grid guard and it is covered by the professional association "SMA grid guard" clean report of findings.

|  |   |   |   |
|--|---|---|---|
| <p>Fachausschuss Elektrotechnik<br/>                 der Berufsgenossenschaftlichen Zentrale<br/>                 für Sicherheit und Gesundheit – BGZ<br/>                 des Hauptverbandes der gewerblichen Berufsgenossenschaften</p> <p>Fachausschuss Elektrotechnik, Postfach 51 05 80, 50941 Köln</p> |   |  <p><b>BG</b><br/>                 Federführung:<br/>                 Berufsgenossenschaft<br/>                 der Feinmechanik<br/>                 und Elektrotechnik</p> |   |
| <p><b>SMA Technologie AG</b><br/>                 Hannoversche Straße 1-5<br/>                 34266 Niestetal</p>   |   |   |   |
| <p>Ihre Zeichen/Nachricht vom</p>  | <p>Unser Zeichen (Bitte stets angeben)<br/> <b>UB.010.17</b></p>  | <p>Bearbeiter<br/> <b>PI/Ow</b></p>   | <p>☎ (02 21) 37 78-<br/> <b>6312</b> Datum<br/> <b>25.01.2006</b></p> |
| <p><b>Unbedenklichkeitsbescheinigung</b></p>   |   |   |   |
| <p><b>Erzeugnis:</b></p>   | <p>Selbsttätig wirkende Schaltstelle (ENS)</p>  |   |   |
| <p><b>Typ:</b></p>   | <p>SMA grid guard<br/>                 Version 2</p>  |   |   |
| <p><b>Bestimmungsgemäße Verwendung:</b></p>  | <p>Selbsttätig wirkende, dem VNB unzugängliche Schaltstelle als Sicherheitsschnittstelle zwischen einer Eigenerzeugungsanlage und dem Niederspannungsnetz. Gleichwertiger Ersatz für eine jederzeit dem VNB zugängliche Schaltstelle mit Trennfunktion.</p> |   |   |
| <p><b>Prüfgrundlage:</b></p>   | <p>DIN V VDE V 0126-1-1 (2006-02) "Selbsttätige Schaltstelle zwischen einer netzparallelen Erzeugungsanlage und dem öffentlichen Niederspannungsnetz"</p>   |   |   |
| <p>Das Sicherheitskonzept des o.g. Erzeugnisses, entspricht den zum Zeitpunkt der Ausstellung dieser Bescheinigung geltenden sicherheitstechnischen Anforderungen für die aufgeführte bestimmungsgemäße Verwendung.</p>  |   |   |   |
| <p>Die Unbedenklichkeitsbescheinigung wird spätestens</p> <p style="text-align: center;"><b>31.12.2010</b></p>   |   |   |   |
| <p>ungültig.</p>   |   |   |   |
| <p><br/>                 - Mehlert -<br/>                 Leiter der Prüf- und<br/>                 Zertifizierungsstelle</p>   |   |   |   |
| <p>Hausadresse:</p>  | <p>Gustav-Heinemann-Lufer 130</p>   | <p>50968 Köln</p>   | <p>Tel. (02 21) 37 78-63 01 Fax (02 21) 37 78-63 22</p>               |

## 9 Replacing the Varistors

The possibilities for fixing faults of the Sunny Boy on site are limited to just a few items. Do not attempt to carry out repairs other than those described here. Use the **SMA Technologie AG** 24-hour replacement service and repair service instead.

If the red LED on the status display shines continuously during operation, you should first of all make sure that there is no ground fault in the PV generator.

1. Disconnect the Sunny Boy from the low voltage grid (switch the line circuit breaker to its "off" position). Make sure the grid cannot be inadvertently reconnected and test to make sure no voltage is present on the AC output.

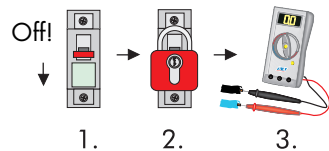

2. Disconnect the DC plug connectors for all strings.

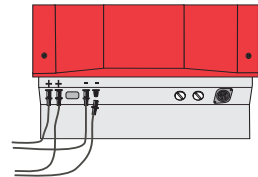

3. Taking one DC plug connector at a time, measure the voltages between one DC plug connector of a string and ground potential. Pay attention to the safety instructions!

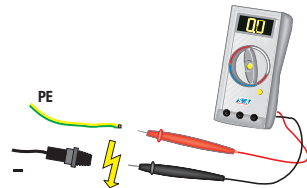

### Warning!

**Dangerously high voltages may be present. Danger of death!**



4. If the measured voltages are constant and their total is roughly the same as the open circuit voltage of the string, then there is a ground fault in this string. Its approximate location can be deduced from the relationships between the voltages.
5. Repeat points 3 and 4 for each string.

If you found a ground fault, it is probably not necessary to replace the varistors. Instead, make sure the ground fault is fixed. Generally the PV generator's installer should be hired for this job. In this case continue as described under point 10, but without reconnecting the faulty string! Instead of reconnecting the string, protect its DC plug against accidental touch contact (e.g. by fitting the protective caps or using sufficient high-voltage insulating tape).

If you did not find any ground fault in the PV generator, it is likely that one of the thermally monitored varistors has lost its protective function. These components are wearing parts. Their functioning diminishes with age or following repeated responses as a result of overvoltages. You can now check these varistors in the following way, paying attention to the safety instructions in section 3 "Safety Instructions" (Page 9):

6. Remove the screws securing the cover and remove the cover from the Sunny Boy. Disconnect the PE connection from the cover. Make sure that no voltage is present.
7. Use a continuity tester to check all the varistors and see if there is a conducting connection between connectors 2 and 3. If there is no connection, then that varistor is not working. The positions of the varistors in the Sunny Boy can be seen in the figure in section 4.1 "Unit Description" (Page 11).

8. Replace the varistor concerned with a new one as shown in the illustration to the right. Ensure the varistor is installed the right way round! If you do not receive a special tool for operating the terminal clamps together with your replacement varistors, contact SMA. As an alternative, the terminal contacts can be operated using a suitable screwdriver. Since the failure of one varistor is generally due to factors that affect all varistors in a similar way (temperature, age, inductive overvoltages), it is highly recommended that you replace both varistors, not just the one that is obviously defective. The varistors are specially manufactured for use in the Sunny Boy and are not commercially available. They must be ordered directly from **SMA** Technologie AG (SMA order code: "SB-TV4").

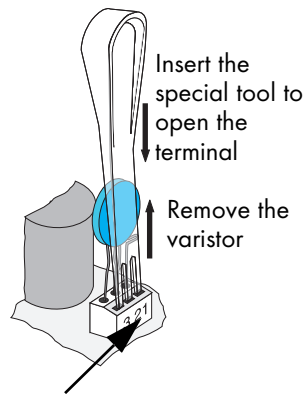

The pole with the small loop (crimp) must be fitted to terminal 1 when replacing the varistor.

9. If no replacement varistors are available on site, the Sunny Boy can be temporarily run without them. To do this, remove the varistors you identified as being faulty and in their place, bridge the terminals 2 and 3 with a length of wire.

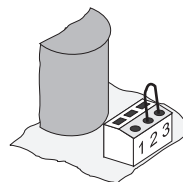



**Warning!**

The input modified in this way is no longer protected against overvoltages! Replacement varistors should be obtained as soon as possible. The Sunny Boy should not be operated without varistors in systems having a high risk of overvoltages!



10. Reconnect the PE connection on the cover and close the Sunny Boy.
11. Connect up the faultless PV generator strings to the inverter.
12. Close the unused DC input sockets with the caps included in the delivery.
13. Switch the line circuit breaker to the "on" position.
14. Now check whether the LED display on the Sunny Boy indicates that the device is functioning correctly.

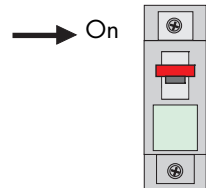
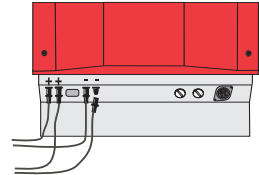

If no ground fault and no defective varistor were found, there is probably a fault in the Sunny Boy. In this case, contact the SMA Hotline to discuss what to do next.



## 10 Rating for a Line Circuit Breaker

Example for the thermal rating for a line circuit breaker in a photovoltaic power-generating system operated in parallel with the low voltage grid



We assume a PV system with 9 Sunny Boy inverters, with three inverters per phase.

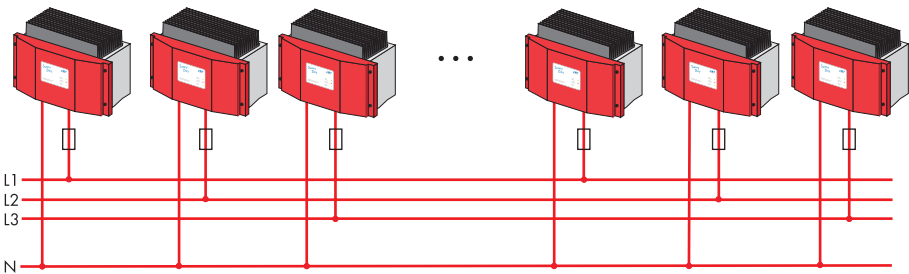

### Required Technical Data for the Inverters Used

- Maximum output current = 11 A
- Maximum permissible fuse protection for the inverter = 16 A

The choice of cable together with the way it is routed, ambient temperatures and other underlying conditions limit the maximum fuse protection for the cable.

- In our example we assume that the chosen cable (2.5 mm<sup>2</sup>) is ideally routed and can take a nominal current of 11 A.

Selecting the line circuit breakers:

- The maximum possible nominal current for the cable used and the maximum possible fuse protection for the inverter now limit the maximum possible nominal current for the line circuit breaker.
- In our example, 10 A is possible.

However, the thermal suitability of the line circuit breaker still needs to be checked.

When selecting line circuit breakers, a number of load factors need to be taken into account. These can be found in the respective data sheets.



Example for the thermal selection of a 10 A line circuit breaker with B sensitivity and no gap between the circuit breakers:

For example, one manufacturer's circuit breaker may be designed for an ambient temperature of 50 °C.

### Load factors according to data sheet specifications:

- Reduction through permanent load >1 h = 0.9<sup>a</sup>
- Reduction factor when 9 circuit breakers are arranged side-by-side without gaps = 0.77<sup>b</sup>
- Increase in nominal current as a result of ambient temperatures of 40 °C in the circuit breaker panel = 1.07<sup>c</sup>

### Result:

The nominal load current for the line circuit breaker is calculated as:

$$I_{bn} = 16 \text{ A} \times 0.9 \times 0.77 \times 1.07 = 11.86 \text{ A}$$

- 
- Permanent loads of longer than 1 hour are possible in photovoltaics.
  - When only one circuit breaker is used, this factor = 1.
  - Due to the fact that the circuit breakers are rated for 50 °C.

## Summary:

The selected line circuit breaker can be used in our example case since the maximum current-carrying capacity for fault-free operation is higher than the maximum output current of the inverter used. It will stop under rated operating conditions!

If the calculated current-carrying capacity of the circuit breaker had been lower than the maximum output current from the inverter, the following solution might have been used:

By spacing the circuit breakers at an interval of 8 mm, the reduction factor would be 0.98 instead of 0.77. As a result, the maximum current-carrying capacity would be 15.1 A.

In addition to the thermal rating of the circuit breakers, the boundary conditions as laid out in section "Rating for a Line Circuit Breaker in a Photovoltaic Power Generating System Operated in Parallel to the Low Voltage Grid" (Page 17) and the applicable DIN VDE standards also need to be taken into account. The main ones that apply here are:

DIN VDE 0100, part 410

DIN VDE 0100, part 430

DIN VDE 0298, part 4

In special applications the relevant standards must be followed!



# 11 The Communication Interface

**Installation or replacement of the communication interface is only to be carried out by a qualified electrician.**



The communication interface is used to communicate with SMA communication devices (e.g. Sunny Boy Control, Sunny WebBox) or a PC with appropriate software (e.g. Sunny Data). Depending on the selected communication interface, up to 2500 inverters can be interconnected. Detailed information on this topic can be found in the communication device manual, the software, or on the Internet at [www.SMA.de](http://www.SMA.de).

*The communication interface connections are designed for safe disconnection in accordance with DIN EN 50178: 1998-04.*



*The RS232 and RS485 communication interface connections are of a short-circuit proof design.*

The detailed wiring diagram for each communication interface can be found in the communication device manual. This wiring diagram includes:

- Details on the required cable type
- Which of the inverter's connections are used
- Whether jumpers need to be mounted, and if so, which jumpers
- Whether the PE needs to be connected to the cable shield

The next pages will describe the following:

- The housing feed-throughs for the communication interface
- The permitted cable route in the Sunny Boy
- The location of the PE connector
- The location of the screw terminals for connecting the communication wires
- The location of the jumper slots
- The location of the interface port

## 11.1 Connection of the Interface

This section describes the installation of the Piggy-Backs for the different Sunny Boy communication systems. RS232 Piggy-Back (SMA order number: 232PB-NR), RS485 Piggy-Back (SMA order number: 485PB-NR), Radio Piggy-Back (SMA order number: BEAMPB-NR), Powerline modem (SMA order number: NLMPB-NR).



**When opening the Sunny Boy, follow all the safety instructions as described in section 3.**



*Electrostatic discharges are an acute danger to the Sunny Boy and to the communication interface. Ground yourself by touching PE before removing the communication interface from the packaging, and before touching any components within the Sunny Boy.*



*Read the communication device manual before beginning installation work. Further wiring details can be found there.*

1. Open the inverter as described in section 7.1.
2. Guide the PG screw fitting over the communication cable.
3. Thread the cable through one of the cable feed-throughs (A) on the Sunny Boy. Use one or two cable feed-throughs, depending on the type of cable used. Use the right-hand housing feed-through for the Radio Piggy-Back.
4. Screw the PG screw fitting onto the Sunny Boy.
5. Sheathe the cable inside the Sunny Boy using the silicone tube provided. The silicone tube is imperative for safety reasons. The interface may not be commissioned without this silicone tube (with the exception of the Radio Piggy-Back).
6. Lay the cable in area (B) as shown in the figure to the right.
7. Ground the cable shield at the PE connector (C) if the connection plan of the communication device indicates this as necessary.
8. Connect the communication wires to the screw terminal strip (D) as described in the connection plan of the communication device. Note down the connector color coding for the respective pin numbers. Connecting the receiver incorrectly can cause the devices to be damaged.
  - Pin 2 color: \_\_\_\_\_
  - Pin 3 color: \_\_\_\_\_
  - Pin 5 color: \_\_\_\_\_
  - Pin 7 color: \_\_\_\_\_



9. Connect the jumpers (E) if the connection plan of the communication device indicates this as necessary. The table below provides an overview of the jumper functions.
10. Plug the communication interface to the left of the board (F).
11. Close the Sunny Boy as described in section 7.2.

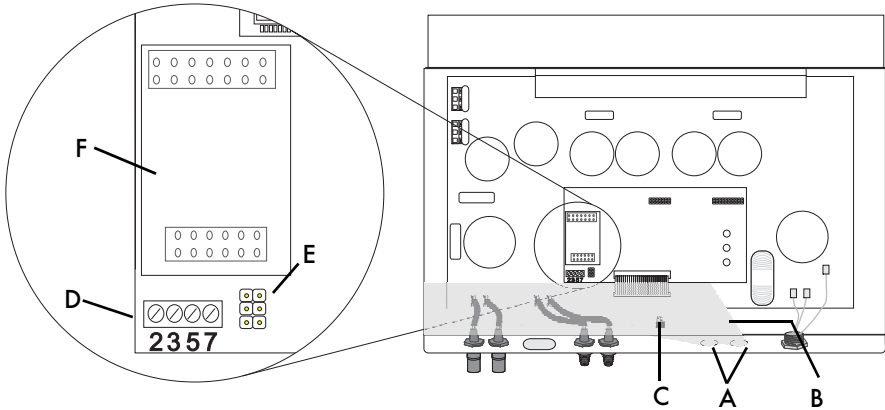

- A Housing feed-throughs in the base of the Sunny Boy
- B Cable route (gray surface)
- C PE connector
- D Screw terminals for connection of the communication wires
- E Jumper slots
- F Interface port

### 11.1.1 Jumper Functions

|                  | Jumper A    | Jumper B | Jumper C |
|------------------|-------------|----------|----------|
| RS232            | -           | -        | -        |
| RS485            | termination | bias 1   | bias 2   |
| Radio Piggy-Back | -           | -        | -        |
| Powerline        | -           | -        | -        |

A detailed description of the jumper functions can be found in the communication device manual.





## 12 Contact

If you have any questions or technical problems concerning the Sunny Boy, contact our hotline. Have the following information available when you contact SMA:

- Inverter type
- Type and number of modules connected
- Communication method
- Serial number of the Sunny Boy
- Blink code of the yellow LED of the Sunny Boy



Address:

**SMA** Technologie AG

Hannoversche Strasse 1 - 5

34266 Niestetal

Germany

Tel.:+49 (561) 95 22 - 499

Fax:+49 (561) 95 22 - 4699

hotline@SMA.de

www.SMA.de

The information contained in this document is the property of SMA Technologie AG. Publishing its content, either partially or in full, requires the written permission of SMA Technologie AG. Any internal company copying of the document for the purposes of evaluating the product or its correct implementation is allowed and does not require permission.

## Exclusion of liability

The general terms and conditions of delivery of SMA Technologie AG shall apply.

The content of these documents is continually checked and amended, where necessary. However, discrepancies cannot be excluded. No guarantee is made for the completeness of these documents. The latest version is available on the Internet at [www.SMA.de](http://www.SMA.de) or from the usual sales channels.

Guarantee or liability claims for damages of any kind are excluded if they are caused by one or more of the following:

- Improper or inappropriate use of the product
- Operating the product in an unintended environment
- Operating the product whilst ignoring relevant, statutory safety regulations in the deployment location
- Ignoring safety warnings and instructions contained in all documents relevant to the product
- Operating the product under incorrect safety or protection conditions
- Altering the product or supplied software without authority
- The product malfunctions due to operating attached or neighboring devices beyond statutory limit values
- In case of unforeseen calamity or force majeure

## Software licensing

The use of supplied software produced by SMA Technologie AG is subject to the following conditions:

This software may be copied for internal company purposes and may be installed on any number of computers. Supplied source codes may be changed or adapted for internal company purposes on your own responsibility. Drivers may also be transferred to other operating systems. Source codes may only be published with the written permission of SMA Technologie AG. Sub-licensing of software is not permissible.

Limitation of liability: SMA Technologie AG rejects any liability for direct or indirect damages arising from the use of software developed by SMA Technologie AG. This also applies to the provision or non-provision of support activities.

Supplied software not developed by SMA Technologie AG is subject to the respective licensing and liability agreements of the manufacturer.

## Trademarks

All trademarks are recognized even if these are not marked separately. Missing designations do not mean that a product or brand is not a registered trademark.

SMA Technologie AG

Hannoversche Straße 1-5

34266 Niestetal

Germany

Tel. +49 561 9522-0

Fax +49 561 9522-100

[www.SMA.de](http://www.SMA.de)

E-mail: [info@SMA.de](mailto:info@SMA.de)

© 2007 SMA Technologie AG. All rights reserved.



**Sales**  
**Solar Technology**

[www.SMA.de](http://www.SMA.de)

**SMA Technologie AG**  
**Hannoversche Strasse 1-5**  
**34266 Niestetal, Germany**  
**Tel.: +49 561 9522 4000**  
**Fax: +49 561 9522 4040**  
**E-mail: [sales@SMA.de](mailto:sales@SMA.de)**  
**Freecall: +800 SUNNYBOY**  
**Freecall: +800 78669269**



Innovation in Systems Technology  
for the Success of Photovoltaics

